

FILTER CLEANING TROUBLESHOOTING

NOTE: Filters can be purchased at a retailer near you, online at www.holmesproducts.com or by calling 1-800-546-5637.

| Air Purifier Model Number | Filter Quantity Needed | Filter Model Number | Filter Description |
|---------------------------|------------------------|---|-----------------------------------|
| HAP8615 / HAP633 | 1 each | HAPF600 (B Filter) HAPF60 (C Filter) | True HEPA Filter Carbon filter |
| HAP8625 | 2 each | HAPF600 (B Filter) HAPF60 (C Filter) | True HEPA Filter Carbon filter |
| HAP8650 | 3 each | HAPF600 (B Filter) HAPF60 (C Filter) | True HEPA Filter Carbon filter |

TIPS & TROUBLESHOOTING

| PROBLEM | SOLUTION |
|-----------------------|---|
| Unit will not operate | <ul style="list-style-type: none"> Make sure unit is properly plugged in and the outlet is energized. If the grill door is not fully closed, the unit will not operate. Make sure the filters are properly installed and firmly close the grill door by pushing on its right side. Check to make sure the unit is on by turning the knob onto a desired speed setting. |
| Decreased air flow | <ul style="list-style-type: none"> Check to ensure nothing is blocking air inlet and filtered air outlet. If the Filter Life Monitor light is red, the filters need to be changed. If the filters have not been changed in a year or more, change the HEPA filters. Ensure carbon filters are changed every 3-6 months. |
| Excessive Noise. | <ul style="list-style-type: none"> Make sure parts are firmly positioned in place. Remove plastic bags from filters, if applicable. |

If you have any questions regarding your product or would like to learn more about other Holmes® products, please contact our Consumer Service Department at 1-800-546-5637 or visit our website at www.holmesproducts.com. For inquiries regarding recycling and proper disposal of this product, please contact your local waste management facility.

© 2016 Sunbeam Products, Inc. doing business as Jarden Consumer Solutions. All Rights Reserved.
Distributed by Sunbeam Products, Inc. doing business as Jarden Consumer Solutions, Boca Raton, Florida 33431.
Sunbeam Products, Inc. is a subsidiary of Newell Brands Inc. (NYSE: NWL)

WARRANTY INFORMATION

5 YEAR LIMITED WARRANTY

Sunbeam Products, Inc. doing business as Jarden Consumer Solutions or if in Canada, Sunbeam Corporation (Canada) Limited doing business as Jarden Consumer Solutions (collectively "JCS") warrants that for a period of five years from the date of purchase, this product will be free from defects in material and workmanship. JCS, at its option, will repair or replace this product or any component of the product found to be defective during the warranty period. Replacement will be made with a new or remanufactured product or component. If the product is no longer available, replacement may be made with a similar product of equal or greater value. This is your exclusive warranty. Do NOT attempt to repair or adjust any electrical or mechanical functions on this product. Doing so will void this warranty.

This warranty is valid for the original retail purchaser from the date of initial retail purchase and is not transferable. Keep the original sales receipt. Proof of purchase is required to obtain warranty performance. JCS dealers, service centers, or retail stores selling JCS products do not have the right to alter, modify or any way change the terms and conditions of this warranty.

This warranty does not cover normal wear of parts or damage resulting from any of the following: negligent use or misuse of the product, use on improper voltage or current, use contrary to the operating instructions, disassembly, repair or alteration by anyone other than JCS or an authorized JCS service center. Further, the warranty does not cover: Acts of God, such as fire, flood, hurricanes and tornadoes.

What are the limits on JCS's Liability?

JCS shall not be liable for any incidental or consequential damages caused by the breach of any express, implied or statutory warranty or condition.

Except to the extent prohibited by applicable law, any implied warranty or condition of merchantability or fitness for a particular purpose is limited in duration to the duration of the above warranty.

JCS disclaims all other warranties, conditions or representations, express, implied, statutory or otherwise.

JCS shall not be liable for any damages of any kind resulting from the purchase, use or misuse of, or inability to use the product including incidental, special, consequential or similar damages or loss of profits, or for any breach of contract, fundamental or otherwise, or for any claim brought against purchaser by any other party.

Some provinces, states or jurisdictions do not allow the exclusion or limitation of incidental or consequential damages or limitations on how long an implied warranty lasts, so the above limitations or exclusion may not apply to you.

This warranty gives you specific legal rights, and you may also have other rights that vary from province to province, state to state or jurisdiction to jurisdiction.

How to Obtain Warranty Service

In the U.S.A.

If you have any questions regarding this warranty or would like to obtain warranty service, please call 1-800-546-5637 and a convenient service center address will be provided to you.

In Canada

If you have any questions regarding this warranty or would like to obtain warranty service, please call 1-800-546-5637 and a convenient service center address will be provided to you.

In the U.S.A., this warranty is offered by Sunbeam Products, Inc. doing business as Jarden Consumer Solutions located in Boca Raton, Florida 33431. In Canada, this warranty is offered by Sunbeam Corporation (Canada) Limited doing business as Jarden Consumer Solutions, located at 20 B Hereford Street, Brampton, Ontario L6Y 0M1. If you have any other problem or claim in connection with this product, please write our Consumer Service Department. **PLEASE DO NOT RETURN THIS PRODUCT TO ANY OF THESE ADDRESSES OR TO THE PLACE OF PURCHASE.**

190648 Rev. A

HAP8615_HAP8625_HAP8650_HAP633_16EM2

Printed In China

GCDS-HOL49189-BB

Holmes®

Owner's Guide
HAP8615/HAP8625
HAP633/HAP8650/HAP8650B



True HEPA

Allergen Remover

PLEASE READ AND SAVE THESE IMPORTANT INSTRUCTIONS

IMPORTANT SAFEGUARDS

When using electrical appliances, basic safety precautions should always be followed to reduce the risk of fire, electric shock, and injury to persons. These precautions include:

1. Read all instructions before using the appliance.
2. To avoid fire or shock hazard, plug the appliance directly into a 120V AC electrical outlet.
3. If the filter is covered by a bag when shipped, remove plastic bag before use.
4. Keep the cord out of heavy traffic areas. To avoid fire hazard, NEVER put the cord under rugs, near heat registers, radiators, stoves, or heaters.
5. To protect against electrical hazards, DO NOT immerse in water or other liquids. Do not use near water.
6. Close supervision is necessary when any appliance is used by or near children, or disabled persons.
7. Always unplug the air purifier before moving or cleaning the unit, opening the grill, changing the filters and whenever the unit is not in use. To disconnect the unit, be sure to pull the plug and not the cord.
8. NEVER drop or insert any objects into the openings of the unit.
9. Do not operate any appliance with a damaged cord or plug. If the motor fan fails to operate or the unit has been dropped or damaged in any manner, return appliance to manufacturer for examination and / or repair.
10. Use appliance only for intended household use as described in this manual. Any other use not recommended by the manufacturer may cause fire, electric shock, or injury to persons. The use of attachments not recommended or sold by Jarden Consumer Solutions may cause hazards.
11. DO NOT use outdoors.
12. NEVER place on a soft surface such as a bed or sofa as this could cause the unit to tip over and block the air inlet or outlet grills.

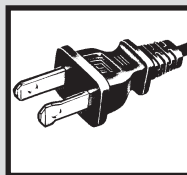

THIS APPLIANCE HAS A POLARIZED PLUG (one blade is wider than the other). To reduce the risk of electric shock, this plug is intended to fit in a polarized outlet only one way. If the plug does not fit fully in the outlet, reverse the plug. If it still does not fit, contact a qualified electrician to install the proper outlet.

DO NOT ATTEMPT TO MODIFY THIS PLUG OR DEFEAT THIS SAFETY FEATURE IN ANY WAY.

13. Keep unit away from heated surfaces and open flames.
14. DO NOT attempt to repair or adjust any electrical or mechanical functions on this unit. Doing so may cause injuries and void your warranty. The inside of the unit contains no user serviceable parts. All servicing should be performed by Jarden Consumer Solutions or an authorized Jarden Consumer Solutions Center.
15. DO NOT place anything on top of unit.
16. Always turn the appliance off before unplugging it.
17. Always turn the appliance off before unplugging it.
18. This appliance should only be used in a room with temperatures between 40° F and 110° F.
19. To reduce the risk of fire or electric shock, DO NOT use this appliance with any solid-state speed control device.

SAVE SAFETY INSTRUCTION

POWER CORD INSTRUCTIONS

- The length of cord used on this appliance was selected to reduce tangling or tripping hazards.
- If a longer cord is necessary, an approved extension cord may be used. The electrical rating of the extension cord must be equal to or greater than the electrical rating of the air purifier (see rating label marked on product).
- Care must be taken to arrange the extension cord so that it will not drape over the countertop or tabletop where it can be pulled on by children or accidentally tripped over.

FEATURES

GET TO KNOW YOUR AIR PURIFIER

Your true HEPA air cleaner removes up to 99.97% of airborne allergens as small as 0.3 microns, such as ragweed pollen, grass pollen, tree pollen, household dust, dust mite debris, mold spores, pet dander and smoke from the air passing through the filter.

TRUE HEPA FILTER

HEPA (High Efficiency Particulate Air) filters are designed to remove up to 99.97% of airborne pollutants at 0.3 microns or larger, from the air that passes through them. These include tobacco smoke, household dust, pet dander, and pollen.

HIGH, MEDIUM, LOW AND SLEEP SPEED SETTINGS

For optimum air filtration, operate your Holmes® Air Purifier continuously on the MEDIUM (3) setting. For quieter operation (such as in a bedroom), select LOW (2) or SLEEP (1) setting. When high levels of allergens are present, select the HIGH (4) setting.

FILTER LIFE MONITOR

The Filter Life Monitor uses a series of lights to give you an indication of the remaining filter life. When the filters are new and in good condition, the top light will be illuminated green. As the filter life progresses, the Filter Life Monitor will move to yellow. At this point, the carbon and HEPA filters should be checked. When the Filter Life Monitor light is red, it is time to change the filters.

DUAL POSITION

The air purifier can stand upright or lie on its side. Also designed to fit with its back flush against the wall. When positioning the unit, please be sure the air inlet grill, filters and air outlet are not blocked to ensure maximum airflow.

PRE-OPERATING INSTRUCTIONS

NOTE: The door should not be opened when the unit is on its side.

1. After removing the unit from the box, take the plastic covering off the unit and properly dispose of it.
2. Lay the air purifier flat on its back with the front grill pointing up.
3. Open the front grill door of the air purifier by gently pulling it forward.
4. The carbon filters, which are packed in a plastic bag in the box, should be removed from the bag and then placed on each of the pre-installed HEPA filters. The plastic tabs on HEPA filters will hold the carbon filters in place (see Figure 1).
5. Close the front grill door by pushing firmly against the right hand side of the door.

Figure 1

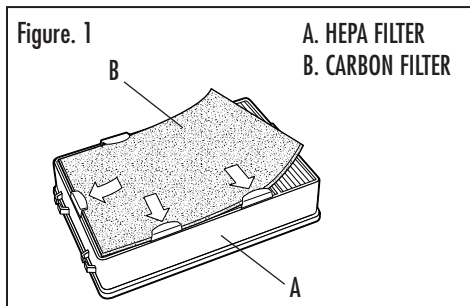

A. HEPA FILTER
B. CARBON FILTER

OPERATING INSTRUCTIONS

IMPORTANT:

- Remove all plastic bags from filters before use.
- DO NOT POINT FILTERED AIR OUTLET TOWARDS WALL.

To operate your air purifier:

1. Select location where air intake grill and filtered air outlet are not obstructed.
2. Plug into a 120V AC electrical outlet.
3. The air purifier is now ready for use. Set the air purifier to the desired speed setting; HIGH (4), MEDIUM (3), LOW (2) or SLEEP (1) by turning the speed control knob.

CLEANING / MAINTENANCE

Figure 2

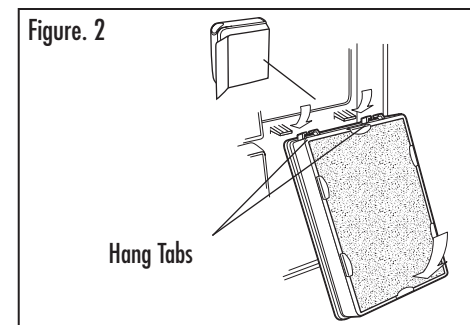

Figure 3

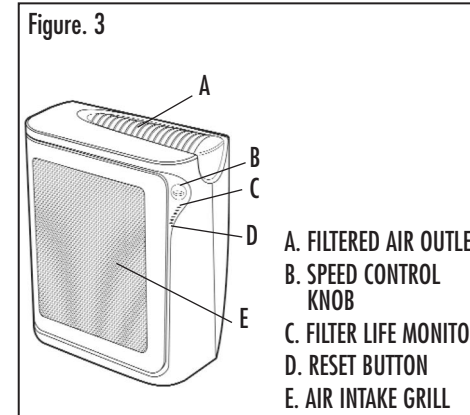
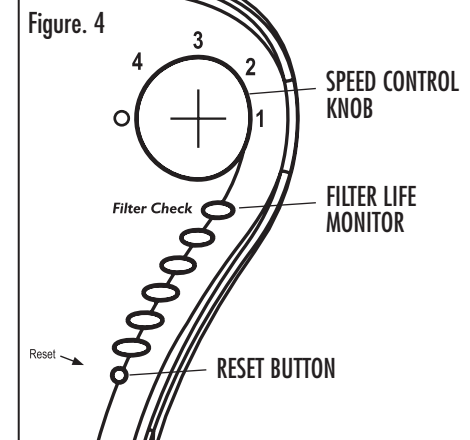

Figure 4



CLEANING / MAINTENANCE INSTRUCTIONS

1. Turn the air purifier off and unplug it before cleaning.
 2. The outside of the air purifier can be cleaned with a soft, clean damp cloth.
 3. The filtered air outlet / top air vent can be cleaned of dust with a small, soft brush.
 4. If you wish to clean the inside of the air purifier, please remove filters and only use a dry, soft cloth to wipe it down.
 5. DO NOT wash filters.
- WARNING:** Do not allow moisture to come in contact with the main housing of the air purifier.

FILTER REPLACEMENT INSTRUCTIONS

IMPORTANT:

- **NOTE:** DO NOT attempt to wash and re-use HEPA filters.
- If new filters are enclosed in plastic bags, remove them before use.

NOTE: On average, HEPA filters need to be replaced every 12-18 months. Carbon filters need to be replaced every 3-6 months. Filter life will vary depending on air quality and usage.

1. Turn off and unplug the air purifier.
2. For models with the pre-filter (HAP633 & HAP8650), periodically check the condition of the foam pre-filter by opening the front grill door and examining it. Remove any dust or lint from the pre-filter by washing it in warm soapy water. Rinse and drip dry. Replace the pre-filter and secure it with the latch frame on the front grill door.
3. Remove each of the filters from the unit by pulling gently towards you.
4. To replace carbon filters, simply remove the old carbon filter and insert a new carbon in its place, using the plastic tabs as a guideline (see Figure 1).
5. DO NOT attempt to clean the old HEPA filter. To replace HEPA filters, discard the old HEPA filters. Put the carbon filter back on the new HEPA filter. Insert the new HAPF600 HEPA filter into the unit, by sliding it onto the hang tabs. (see Figure 2)
6. Close the front grill door by pushing firmly against the right hand side of the door.
7. After replacing the HEPA filters, RESET the Filter Life Monitor by inserting a small object (such as a pin or paper clip) into the hole below the red filter change light marked RESET and holding it down for 2-3 seconds.