

## CLEANING & MAINTENANCE

4. To clean the HEPA-type permanent filter, remove the dirty filter. Using your vacuum cleaner, run the brush attachment along both sides of the filter and clean between the pleated layers (Figure 4). After cleaning, reinstall the cleaned HEPA-type permanent filter back into the unit.
- IMPORTANT:** Do not use water, household cleaners or detergents to clean the HEPA-type permanent filter. Should the HEPA-type permanent filter become damaged during cleaning, replacements are available by calling 1-800-546-5637.
5. Install the rear grill back onto the unit and securely latch it in place. (see Figure 5).

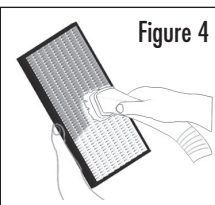

Figure 4

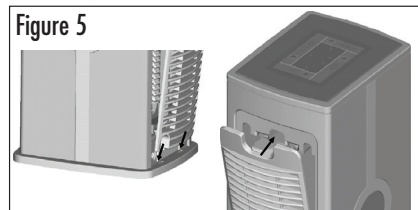

Figure 5

**NOTE:** All filters and rear grill must be properly installed to the unit. If either the grill or the filter is not properly installed, the unit will not operate.

### UV BULB WARNINGS:

- Ultraviolet-C light is emitted from the bulb when the unit is plugged in. DO NOT expose eyes or skin to direct light from ultraviolet light. Severe eye injury or irritation could result.
- UV bulb contains mercury. If the bulb breaks, DO NOT vacuum or handle with your bare hands. Carefully sweep debris into a plastic bag and dispose properly at your local hazardous waste collection site.
- DO NOT attempt under any circumstance to clean the bulb, bulb holder or cover with water or wet solutions. This could result in electrical shock.
- DO NOT attempt to remove UV bulb as risk of breakage and injury may occur.

## TROUBLESHOOTING

### TIPS AND TROUBLESHOOTING

Problem	Solution
• Unit will not operate	<ul style="list-style-type: none"> <li>✓ Make sure the unit is connected with the power adaptor and the adaptor is plugged in and outlet is energized.</li> <li>✓ Make sure unit is turned on.</li> </ul> The unit has safety features in place to ensure the unit is ready for operation: <ul style="list-style-type: none"> <li>✓ Check to be sure the UV lamp and UV lamp holder are properly installed;</li> <li>✓ Ensure that all filters are firmly in place;</li> <li>✓ Confirm that the rear grill is latched firmly into place.</li> </ul>
• Decreased air flow	<ul style="list-style-type: none"> <li>✓ Make sure nothing is blocking air inlet and filtered air outlets.</li> <li>✓ Remove all plastic bags from filters.</li> <li>✓ Check condition of filters and clean/replace if necessary.</li> </ul>
• Excessive noise	<ul style="list-style-type: none"> <li>✓ Remove plastic bags from filters.</li> <li>✓ Make sure all parts are firmly positioned in place.</li> </ul>

### REPLACEMENT PARTS

If filters become damaged, replacement parts can be purchased online at [www.holmesproducts.com](http://www.holmesproducts.com), or by calling 1-800-546-5637.

Air Purifier Model #	Quantity Needed	Replacement Part #	Description
HAP3000UV	1	164357	Permanent HEPA Filter
	1	164358	Carbon Filter
	1	164359	Photocatalytic(PCO) Filter

### LEARNING MORE

For a wealth of information about your air purifier and other Holmes® products, visit our website at [www.holmesproducts.com](http://www.holmesproducts.com) or call 1-800-546-5637.

© 2012 Sunbeam Products, Inc. doing business as Jarden Consumer Solutions. All Rights Reserved. Distributed by Sunbeam Products, Inc. doing business as Jarden Consumer Solutions, Boca Raton, Florida 33431.

163727  
GCDS-BIO27523-ZZ

HAP3000UV\_12EM1

Printed In China

## WARRANTY INFORMATION

### 3 YEAR LIMITED WARRANTY

Sunbeam Products, Inc. doing business as Jarden Consumer Solutions or if in Canada, Sunbeam Corporation (Canada) Limited doing business as Jarden Consumer Solutions (collectively "JCS") warrants that for a period of three years from the date of purchase, this product will be free from defects in material and workmanship. JCS, at its option, will repair or replace this product or any component of the product found to be defective during the warranty period. Replacement will be made with a new or remanufactured product or component. If the product is no longer available, replacement may be made with a similar product of equal or greater value. This is your exclusive warranty. DO NOT attempt to repair or adjust any electrical or mechanical functions on this product. Doing so will void this warranty. This warranty is valid for the original retail purchaser from the date of initial retail purchase and is not transferable. Keep the original sales receipt. Proof of purchase is required to obtain warranty performance. JCS dealers, service centers, or retail stores selling JCS products do not have the right to alter, modify or any way change the terms and conditions of this warranty.

This warranty does not cover normal wear of parts or damage resulting from any of the following: negligent use or misuse of the product, use on improper voltage or current, use contrary to the operating instructions, disassembly, repair or alteration by anyone other than JCS or an authorized JCS service center. Further, the warranty does not cover: Acts of God, such as fire, flood, hurricanes and tornadoes.

#### What are the limits on JCS's Liability?

JCS shall not be liable for any incidental or consequential damages caused by the breach of any express, implied or statutory warranty or condition.

Except to the extent prohibited by applicable law, any implied warranty or condition of merchantability or fitness for a particular purpose is limited in duration to the duration of the above warranty.

JCS disclaims all other warranties, conditions or representations, express, implied, statutory or otherwise.

JCS shall not be liable for any damages of any kind resulting from the purchase, use or misuse of, or inability to use the product including incidental, special, consequential or similar damages or loss of profits, or for any breach of contract, fundamental or otherwise, or for any claim brought against purchaser by any other party.

Some provinces, states or jurisdictions do not allow the exclusion or limitation of incidental or consequential damages or limitations on how long an implied warranty lasts, so the above limitations or exclusion may not apply to you.

This warranty gives you specific legal rights, and you may also have other rights that vary from province to province, state to state or jurisdiction to jurisdiction.

#### How to Obtain Warranty Service

##### In the U.S.A.

If you have any questions regarding this warranty or would like to obtain warranty service, please call 1-800-546-5637 and a convenient service center address will be provided to you.

##### In Canada

If you have any questions regarding this warranty or would like to obtain warranty service, please call 1-800-546-5637 and a convenient service center address will be provided to you.

In the U.S.A., this warranty is offered by Sunbeam Products, Inc. doing business as Jarden Consumer Solutions located in Boca Raton, Florida 33431. In Canada, this warranty is offered by Sunbeam Corporation (Canada) Limited doing business as Jarden Consumer Solutions, located at 20 B Hereford Street, Brampton, Ontario L6Y 0M1. If you have any other problem or claim in connection with this product, please write our Consumer Service Department. **PLEASE DO NOT RETURN THIS PRODUCT TO ANY OF THESE ADDRESSES OR TO THE PLACE OF PURCHASE.**

# Holmes®

## Owner's Guide

HAP3000UV



## HEPA-Type Permanent Filter

# Air Purifier

**PLEASE READ AND SAVE THESE IMPORTANT INSTRUCTIONS**

## IMPORTANT SAFEGUARDS

When using electrical appliances, basic safety precautions should always be followed to reduce the risk of fire, electric shock, and injury to persons. These precautions include:

- Read all instructions before using the appliance.
- To avoid fire or shock hazard, plug the appliance directly into a 120V AC electrical outlet.
- If the filter is covered by a bag when shipped: Remove plastic bag before use.
- Keep the cord out of heavy traffic areas. To avoid fire hazard, NEVER put the cord under rugs, near heat registers, radiators, stoves, or heaters.
- To protect against electrical hazards, DO NOT immerse in water or other liquids. Do not use near water.
- Close supervision is necessary when any appliance is used by or near children, or disabled persons.
- Always unplug the air cleaner before moving or cleaning the unit, opening the grill, changing the filters and whenever the unit is not in use. To disconnect the unit, be sure to pull the plug and not the cord.
- NEVER drop or insert any objects into the openings of the unit.
- Do not operate any appliance with a damaged cord or plug. If the motor fan fails to operate or the unit has been dropped or damaged in any manner, return appliance to manufacturer for examination and/or repair.
- Use appliance only for intended household use as described in this manual. Any other use not recommended by the manufacturer may cause fire, electric shock, or injury to persons. The use of attachments not recommended or sold by the manufacturer may cause hazards.
- DO NOT use outdoors.

- NEVER place on a soft surface such as a bed or sofa as this could cause the unit to tip over and block the air inlet or outlet grills.
- Keep unit away from heated surfaces and open flames.
- DO NOT place anything on top of unit.
- DO NOT attempt to repair or adjust any electrical or mechanical functions on this unit. Doing so will void your warranty. The inside of the unit contains no user serviceable parts. All servicing should be performed by Jarden Consumer Solutions or an authorized Jarden Consumer Solutions Service Center.
- **WARNING:** To reduce the risk of fire or electric shock, DO NOT use this air cleaner with any solid-state speed control device.
- Always turn the appliance off before unplugging it.
- NEVER use detergents, gasoline, glass cleaner, furniture polish, paint thinner or other household solvents to clean any part of the air cleaner.
- The ionizer in this appliance produces less ozone than the UL established limits of 50ppb (parts per billion). However, in high concentrations, ozone can be harmful to birds and small pets. To prevent ozone buildup, we suggest using the ionizer in well ventilated areas with the fan on.
- This appliance should only be used in a room with temperatures between 40° F and 110° F.

## PLEASE SAVE THESE IMPORTANT SAFETY INSTRUCTIONS

## IMPORTANT SAFEGUARDS - FEATURES - OPERATIONS

### BEFORE USE

1. Carefully unpack your air purifier.
2. Select a firm, level surface with no obstructions to the air inlets or outlets.
3. Both HEPA and carbon filters are covered by a plastic bag to protect their freshness. Before using your purifier, **REMOVE THESE PROTECTIVE PLASTIC BAGS FROM FILTERS:**
  - Open the back grill of the air purifier by gently pulling it towards you. Gently lift the back grill to remove. (see Figure 3).
  - After removing the plastic bags, reassemble the filters to unit.
  - Carbon filter should follow the PCO filter, then the HEPA filter, then the pre-filter.
  - Reinstall the back grill. (see Figure 5).
4. Connect the power adaptor to the power jack (under rear grill) on the air purifier, and plug the power adaptor into a 120V AC outlet.

### GET TO KNOW YOUR AIR PURIFIER

#### YOUR HOLMES® AIR PURIFIER FEATURES: ULTRAVIOLET LIGHT

This air purifier uses a UV-C bulb.

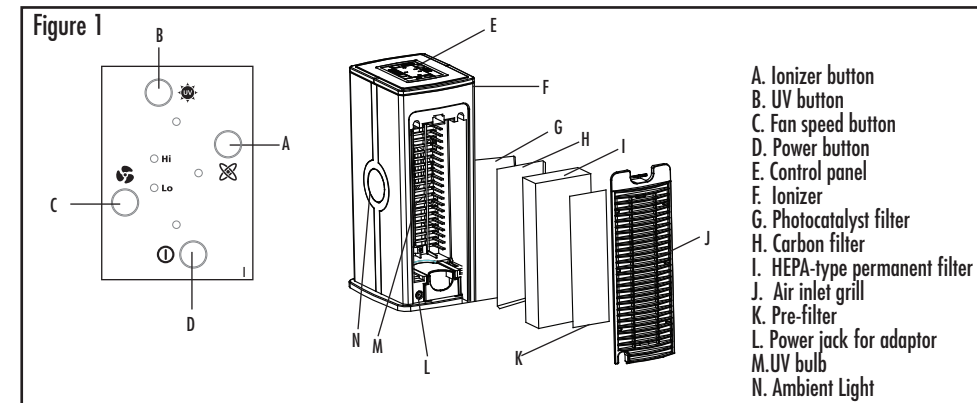

### HEPA-TYPE PERMANENT FILTER

HEPA-type permanent filter removes up to 99% of airborne allergens as small as 2 microns, including ragweed pollen, grass pollen, tree pollen, household dust, dust mite debris, mold spores, pet dander and smoke from the air passing through it. Permanent filter can be vacuumed every few weeks for optimal performance.

### HIGH AND LOW SPEED SETTINGS

For optimum air filtration, operate your Holmes® air purifier continuously on the HIGH (Hi) setting. For quieter operation (such as in a bedroom), select the LOW (Lo) setting.

### OPTIONAL IONIZER

This appliance has an ionizer, which releases negative ions into outgoing filtered air to help the air purification process.

### What Are Ions?

Ions are tiny particles that carry a positive or negative charge. They exist naturally around us: in the air, water, and ground. Both positive and negative ions are colorless, odorless, and completely harmless to humans.

## FEATURES

### How Does The Ionizer Work?

Negative ions help air purification by attaching themselves to very small airborne particles in the room. These particles take on a negative charge and may join with positively charged particles such as dust, pollen, smoke, and pet dander to form larger particles. These larger particles are then more easily captured by the filter system.

### Important Notes:

- Your ionizer may produce an occasional popping or cracking sound. This is normal and occurs when a small buildup of ions is discharged.
- After extended use, you may notice dust around the grills or front panel. This is caused by negative ions exiting the air outlet, evidence of the ionizer's air cleaning effectiveness. You can remove the dust with a soft brush or clean, damp cloth.
- Larger particles may be attracted to positively charged surfaces throughout the home, like walls or floors. This may occur more frequently when the filter is nearing the end of its useful product life and unable to capture as many charged particles.
- Excessive amounts of pet dander, dust, or smoke may decrease the life expectancy of the filter and interfere with the ionization process.

**CAUTION:** The ionizer in this appliance produces less ozone than the UL established limits of 50ppb. However, in high concentrations, ozone can be harmful to birds and small pets. To prevent ozone buildup, we suggest using the ionizer in well ventilated areas with the fan on.

**IMPORTANT:** Always clean the filter at the recommended intervals (See Cleaning and Maintenance). Using the ionizer with dirty filters may result in dirty particles exiting the air purifier and attracting to walls, carpets, furniture, or other household objects. These dirty particles may prove difficult to remove.

### HOW YOUR AIR PURIFIER WORKS

#### 5-Stage Air Purification System

Your air purifier uses a five-stage air purification system to help purify the air that passes through the filter (see Figure 2):

**STAGE 1** - The air first flows through the pre-filter and captures larger particles, thus extending the life of the HEPA filter.

**STAGE 2** - HEPA-type permanent filter removes up to 99% of airborne allergens as small as 2 microns, including ragweed pollen, grass pollen, tree pollen, household dust, dust mite debris, mold spores, pet dander and smoke from the air passing through it.

**STAGE 3** - Carbon filter absorbs and eliminates common household odors, such as garbage or nursery smells.

**STAGE 4** - Photocatalyst filter combines UV rays with a Titanium Dioxide (TiO<sub>2</sub>) coated filter. This process creates hydroxyl radicals and super-oxide ions, which are highly reactive electrons aggressively combined with other elements in the air, such as VOCs (which include harmful pollutants, such as formaldehyde, ammonia, and many other common contaminants) released by building materials and household cleaners generally found in the home.

#### STAGE 5 - UV Bulb

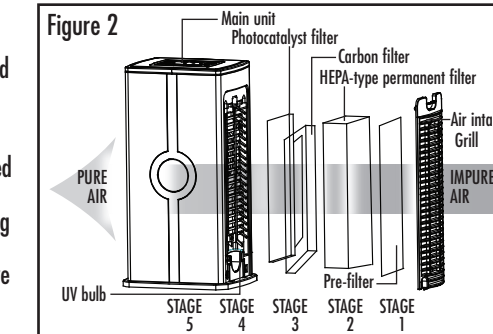

## OPERATIONS - CLEANING & MAINTENANCE

### OPERATING INSTRUCTIONS

#### IMPORTANT:

- Remove all plastic bags from filters before use.
- DO NOT POINT FILTERED AIR OUTLET TOWARDS WALL.

#### To operate your air purifier:

1. Press power button (Ⓚ).
  2. You can change the filtering speed by pressing the Fan speed button (Ⓛ) until you reach the desired speed: Hi-Lo.
  3. To release negative ions into the filtered air, press the ionizer button (Ⓜ) to ON and the light will illuminate.
- NOTE: The ionizer will not work unless the unit is running.
4. When the air purifier is on, UV is default running, Press UV button (Ⓝ) to switch UV ON or OFF.
  5. To turn the air purifier off, press the Power button (Ⓚ).

### USING THE UV LAMP FUNCTION:

To activate this function in any mode, press UV Button (Ⓝ). The UV indicator light (Ⓝ) will illuminate on control panel when this function is activated. To deactivate the feature, press the UV button (Ⓝ) one more time.

**Note:** This unit is equipped with a double safety interlock switch. Removing the rear grill and removing the HEPA filter will cancel the UV light function and turn off the unit.

### CLEANING AND MAINTENANCE

#### Cleaning the unit:

1. Turn off and unplug the air purifier.
2. The outside of the unit can be cleaned with a soft, clean damp cloth.
3. The air inlet grill can be cleaned with a soft, clean damp cloth.
4. The filtered air outlet can be cleaned of dust with a small soft brush.

5. If you wish to clean the filter chamber of the air purifier, please only use a dry, soft cloth to wipe it down. DO NOT WASH Photocatalyst filter and Carbon filter. The Pre-filter (K) can be washed by using a mild dish soap and water. Rinse thoroughly.
6. NEVER use detergents, gasoline, glass cleaner, furniture polish, paint thinner or other household solvents to clean any part of the air purifier.

**WARNING:** Do not allow moisture to come in contact with the main housing of the air purifier.

### FILTER CLEANING/REPLACEMENT INSTRUCTIONS

**Note:** On average, your HEPA-type permanent filter needs to be cleaned every few weeks, it is designed to never need replacement. However, regular cleaning is important for optimal performance, and we also recommend replacement for a new HEPA-type permanent filter after frequent cleaning. Carbon filter needs to be replaced every 3-4 months. Filter life will vary depending on air quality and usage.

1. Turn off and unplug the air purifier before replacing the filters. Remove the rear grill.
2. Remove the filters from the unit by pulling them gently towards you.
3. To replace the carbon filter, simply remove the old carbon filter and insert a new carbon filter in its place after first removing the plastic bag (see figure 3). Use the plastic tabs on the back grill door as a guideline.

