

TROUBLESHOOTING

TROUBLESHOOTING	
Problem	Solution
• Unit will not operate.	✓ Make sure unit is properly plugged in and the outlet is energized. ✓ Make sure the filter is properly installed. ✓ Check to make sure the unit is on by turning the Control Knob to either 1 or 2 position.
• Decreased air flow.	✓ Check to ensure nothing is blocking air inlet and filtered air outlet. ✓ Check the filter to see if it is in good condition and if filter needs to be changed.
• Excessive Noise.	✓ Remove, inspect, and reinstall filter to ensure plastic wrappers are removed and discarded.

LEARNING MORE

For a wealth of information about your air purifier and other Holmes® products, visit our website at www.holmesproducts.com or call 1-800-546-5637.

WARRANTY INFORMATION

1 YEAR LIMITED WARRANTY

Sunbeam Products, Inc. doing business as Jarden Consumer Solutions or if in Canada, Sunbeam Corporation (Canada) Limited doing business as Jarden Consumer Solutions (collectively "JCS") warrants that for a period of one year from the date of purchase, this product will be free from defects in material and workmanship. JCS, at its option, will repair or replace this product or any component of the product found to be defective during the warranty period. Replacement will be made with a new or remanufactured product or component. If the product is no longer available, replacement may be made with a similar product of equal or greater value. This is your exclusive warranty. Do NOT attempt to repair or adjust any electrical or mechanical functions on this product. Doing so will void this warranty. This warranty is valid for the original retail purchaser from the date of initial retail purchase and is not transferable. Keep the original sales receipt. Proof of purchase is required to obtain warranty performance. JCS dealers, service centers, or retail stores selling JCS products do not have the right to alter, modify or any way change the terms and conditions of this warranty.

This warranty does not cover normal wear of parts or damage resulting from any of the following: negligent use or misuse of the product, use on improper voltage or current, use contrary to the operating instructions, disassembly, repair or alteration by anyone other than JCS or an authorized JCS service center. Further, the warranty does not cover: Acts of God, such as fire, flood, hurricanes and tornadoes.

What are the limits on JCS's Liability?

JCS shall not be liable for any incidental or consequential damages caused by the breach of any express, implied or statutory warranty or condition.

Except to the extent prohibited by applicable law, any implied warranty or condition of merchantability or fitness for a particular purpose is limited in duration to the duration of the above warranty.

JCS disclaims all other warranties, conditions or representations, express, implied, statutory or otherwise.

JCS shall not be liable for any damages of any kind resulting from the purchase, use or misuse of, or inability to use the product including incidental, special, consequential or similar damages or loss of profits, or for any breach of contract, fundamental or otherwise, or for any claim brought against purchaser by any other party.

Some provinces, states or jurisdictions do not allow the exclusion or limitation of incidental or consequential damages or limitations on how long an implied warranty lasts, so the above limitations or exclusion may not apply to you.

This warranty gives you specific legal rights, and you may also have other rights that vary from province to province, state to state or jurisdiction to jurisdiction.

How to Obtain Warranty Service

In the U.S.A.

If you have any question regarding this warranty or would like to obtain warranty service, please call 1-800-546-5637 and a convenient service center address will be provided to you.

In the U.S.A., this warranty is offered by Sunbeam Products, Inc. doing business as Jarden Consumer Solutions located in Boca Raton, Florida 33431. If you have any other problem or claim in connection with this product, please write our Consumer Service Department. **PLEASE DO NOT RETURN THIS PRODUCT TO ANY OF THESE ADDRESSES OR TO THE PLACE OF PURCHASE.**

© 2012 Sunbeam Products, Inc. doing business as Jarden Consumer Solutions. All Rights Reserved.
Distributed by Sunbeam Products, Inc. doing business as Jarden Consumer Solutions, Boca Raton, Florida 33431.

158329
GCDS-HOL24898-JC

HAP116Z_12EM1

Printed In China

Holmes®

Owner's Guide

HAP116Z



Personal Space Air Purifier

PLEASE READ AND SAVE THESE IMPORTANT INSTRUCTIONS

IMPORTANT SAFEGUARDS

When using electrical appliances, basic safety precautions should always be followed to reduce the risk of fire, electric shock, and injury to persons. These precautions include:

1. Read all instructions before using the appliance.
2. To avoid fire or shock hazard, plug the appliance directly into a 120V AC electrical outlet.
3. If the filter is covered by a bag when shipped, remove plastic bag before use.
4. Keep the cord out of heavy traffic areas. To avoid fire hazard, NEVER put the cord under rugs, near heat registers, radiators, stoves, or heaters.
5. To protect against electrical hazards, DO NOT immerse the appliance in water or other liquids. Do not use near water.
6. Close supervision is necessary when any appliance is used by or near children, or disabled persons.
7. Always unplug the air purifier before moving or cleaning the unit, opening the grill, changing the filter and whenever the unit is not in use. To disconnect the unit, be sure to pull the plug and not the cord.
8. NEVER drop or insert any objects into the openings of the unit.
9. DO NOT operate any appliance with a damaged cord or plug. If the motor fan fails to operate or the unit has been dropped or damaged in any manner, discard unit or return to an authorized service facility for examination and/or repair.
10. Use appliance only for intended household use as described in this manual. Any other use not recommended by the manufacturer may cause fire, electric shock, or injury to persons. The use of attachments not recommended or sold by Jarden Consumer Solutions may cause hazards.
11. DO NOT use outdoors.
12. NEVER place on a soft surface such as a bed or sofa

13. Keep unit away from heated surfaces and open flames.
14. DO NOT attempt to repair or adjust any electrical or mechanical functions on this unit. Doing so will void your warranty. The inside of the unit contains no user serviceable parts. All servicing should be performed by Jarden Consumer Solutions or an authorized Jarden Consumer Solutions Center.
15. DO NOT place anything on top of unit.
16. NEVER use detergents, gasoline, glass cleaner, furniture polish, paint thinner, or other household solvents to clean any part of the appliance.
17. Always turn the appliance off before unplugging it.
18. This appliance should only be used in a room with temperatures between 40° F and 110° F.
19. **WARNING:** To reduce the risk of fire or electric shock, DO NOT use this appliance with any solid-state speed control device. Do not run cord under carpeting. Do not cover cord with throw rugs, runners, or similar coverings. Do not route cord under furniture or appliances. Arrange cord away from traffic area and where it will not be tripped over.
20. The ionizer in this appliance produces less ozone than the UL established limits of 50ppb (parts per billion). However, in high concentrations, ozone can be harmful to birds and small pets. To prevent ozone buildup, we suggest using the ionizer in well ventilated areas with the fan on.

PLEASE READ AND SAVE THESE IMPORTANT SAFETY INSTRUCTIONS

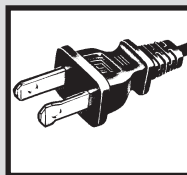

THIS APPLIANCE HAS A POLARIZED PLUG (one blade is wider than the other). To reduce the risk of electric shock, this plug is intended to fit in a polarized outlet only one way. If the plug does not fit fully in the outlet, reverse the plug. If it still does not fit, contact a qualified electrician to install the proper outlet.

DO NOT ATTEMPT TO MODIFY THIS PLUG OR DEFEAT THIS SAFETY FEATURE IN ANY WAY.

FEATURES - OPERATIONS

CORD SAFETY

- The length of cord used on this appliance was selected to reduce tangling or tripping hazards.
- If a longer cord is necessary, an approved extension cord may be used. The electrical rating of the extension cord must be equal to or greater than the electrical rating of the air purifier (see rating label marked on product).
- Care must be taken to arrange the extension cord so that it will not drape over the countertop or tabletop where it can be pulled on by children or accidentally tripped over.

IONIZER

Your Air Purifier has an ionizer, which, when turned on, releases negative ions into outgoing filtered air. Ions are tiny particles that carry a positive or negative charge. These ions exist naturally around us, in the air, water and ground. Both positive and negative ions are colorless, odorless and completely harmless.

Negative ions help the air purification process by attaching themselves to very small airborne particles in the room. These particles take on a negative charge and may join with positively charged particles such as dust, pollen, smoke and pet dander to form larger particles that are then more readily captured by the filter system, or they may be attracted to positively charged surfaces like walls or floors.

You may also note after extended use, that dust may have collected around the grills or front panel. This is from the ionization affect caused by the negative ions exiting from the air outlet.

This is additional evidence of the air cleaning effectiveness of negative ions. The dust can be easily removed with a clean, damp cloth or soft brush.

CAUTION: The ionizer in this appliance produces less ozone than the UL established limits of 50ppb. However, in high concentrations, ozone can be harmful to birds and small pets. To prevent ozone buildup, we suggest using the ionizer in well ventilated areas with the fan on.

NOTE: It is important to replace the filter at the recommended intervals. Using the ionizer in conjunction with dirty filters may result in dirty particles exiting the

air purifier and being attracted to walls, carpets, furniture or other household objects. These dirty particles may prove very difficult to remove.

BEFORE USE

1. Carefully unpack your Air Purifier. Select a firm level place where there are no obstructions to the air inlet or filtered air outlet.
2. Check the rear side of the unit to see if the filter is covered by a plastic bag. If it is, remove plastic bag before use and place filter into unit.
3. DO NOT POINT FILTERED AIR OUTLET TOWARDS WALL.

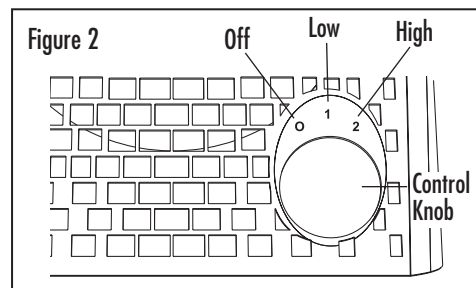
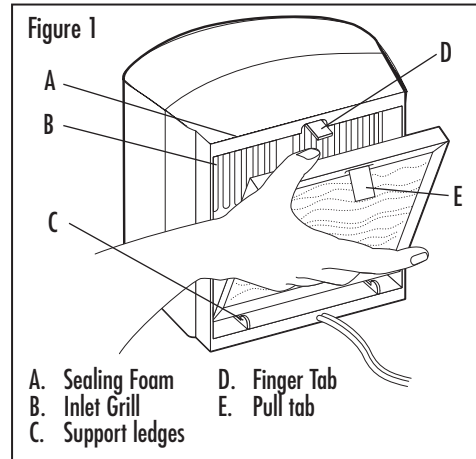

OPERATIONS - CLEANING / MAINTENANCE

OPERATING INSTRUCTIONS

1. Plug into a 120V AC electrical outlet.
2. Turn the Control Knob to select the desired airflow speed setting:
0 - Off
1 - Low: for continuous quiet operation
2 - High: for maximum air cleaning

CLEANING / MAINTENANCE INSTRUCTIONS

1. Turn the air purifier off and unplug it before cleaning.
2. The outside of the air purifier can be cleaned with a soft, clean dampened cloth.
3. The filtered air outlet can be cleaned of dust with a small, soft brush.
4. If you wish to clean the inside of the air purifier, please remove filter and only use a dry, soft cloth to wipe it down.
5. DO NOT wash filter.
WARNING: Do not allow moisture to come in contact with the main housing of the air purifier.

FILTER REPLACEMENT INSTRUCTIONS

To keep your Holmes® Air Purifier operating at its peak efficiency, the multi-stage filter cartridge should be replaced on a regular basis. While the length of time between filter changes will vary based on the amount of use and the conditions in which the unit is run, it will be approximately every three months. To change the filter, use the following steps. Remember, always unplug the unit when cleaning it or changing the filter.

1. Looking at the back of the unit, notice the unit's plastic finger tab at the top of the filter and a pull tab on the filter. Gently pull up on the finger tab while pulling on the filter tab. The filter should pull away from the unit.
2. Discard the used filter, gently wipe the inlet grill taking care not to damage the foam.
3. Remove the replacement filter from its packaging and its sealed bag. Mark on the "Replacement Filter" sticker the date on which the filter should likely be replaced. This date should be approximately three months from date of installation.
4. Install the filter by placing the white side towards the unit and introducing the bottom of the filter into the filter cavity. The filter will be resting against the sealing foam and on the filter support ledges.
5. Pivot the top of the filter towards the unit and push it into position. The filter tab should latch on the filter.

Filter can be purchased at a retailer near you, online at www.holmesproducts.com, or by calling 1-800-546-5637.

Air Purifier Model Number	Filter Quantity Needed	Filter Model Number	Filter Description
HAP116Z	1 each	HAPF115 E Filter	HEPA-type Filter